

SECCION 1 SISTEMAS DE SOPORTERIA PARA CABLES

SECTION 1 CABLE TRAY SYSTEM

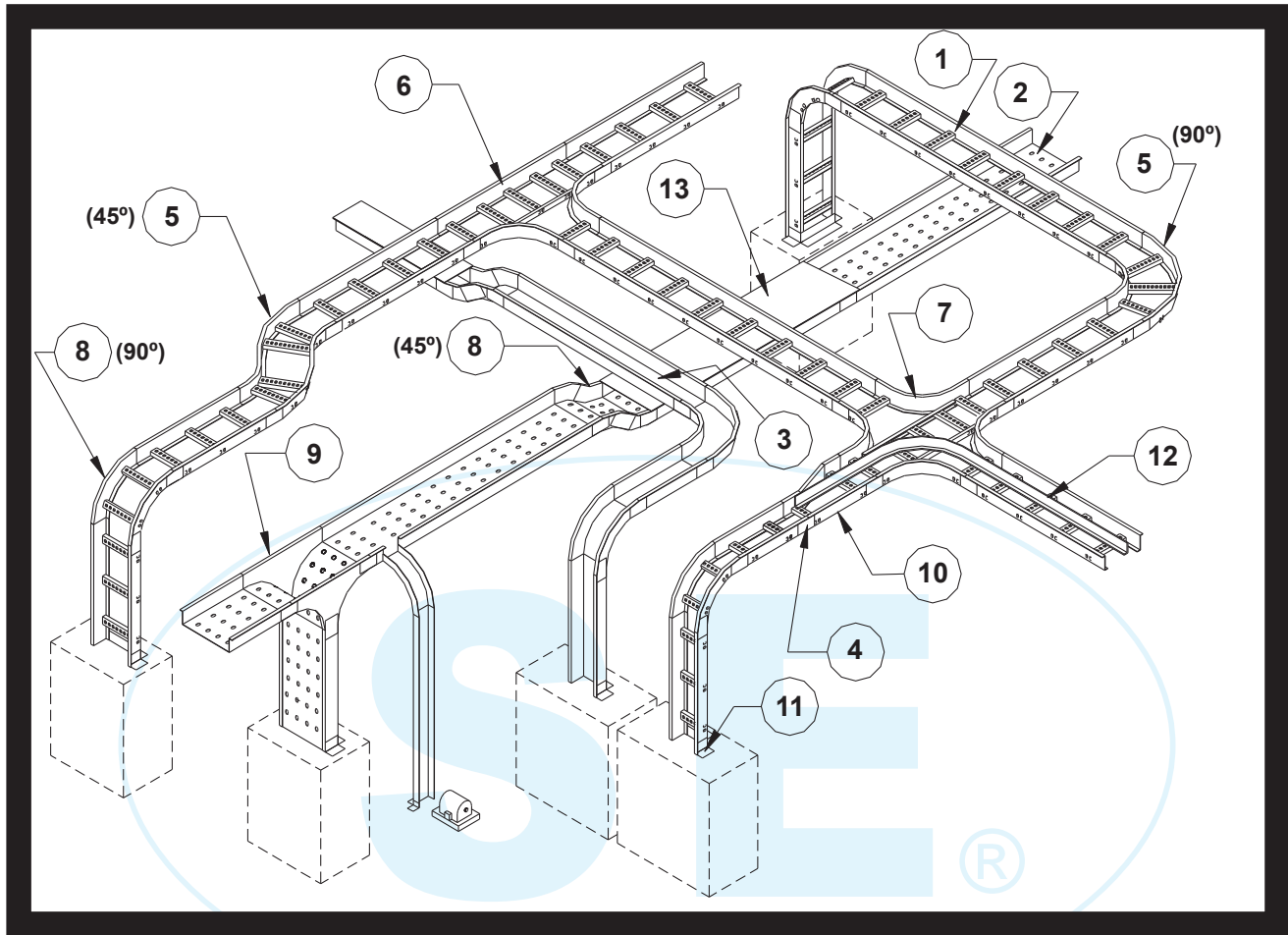

1.- CHAROLA TIPO ESCALERA
LADDER TYPE CABLE TRAY

2.- CHAROLA TIPO TIPO FONDO SOLIDO
PERFORADO
VENTILATED SOLID FLAT BOTTOM
CABLE TRAY

3.- CHAROLA TIPO TIPO FONDO SOLIDO
LISO
SOLID FLAT BOTTOM CABLE TRAY

4.- CONECTOR
SPLICE PLATE

5.- CURVA HORIZONTAL
HORIZONTAL BEND

6.- "T" HORIZONTAL
HORIZONTAL TEE

7.- EQUIS HORIZONTAL
HORIZONTAL CROSS

8.- CURVA VERTICAL INTERIOR
Y EXTERIOR
VERTICAL OUTSIDE AND INSIDE
BEND

9.- "T" VERTICAL
VERTICAL TEE

10.- REDUCCION
REDUCER

11.- CONECTOR DE CHAROLA A CAJA
FRAME TYPE BOX CONNECTOR

12.- BARRERA SEPARADORA
BARRIER STRIP STRAIGHT SECTION

13.- TAPAS (CUBIERTAS)
COVERS



SECCION 1.1 SOPORTERIA PARA CABLES TIPO ESCALERA

SECTION 1.1 CABLE TRAY SYSTEM LADDER TYPE

SECCIONES TIPO "Z"

PERALTE NOMINAL SIDE RAIL HEIGHT	PERALTE UTIL LOADING DEPTH	PERFIL TIPO RAIL TYPE	SUBFIJO P/PERALTE RAIL HEIGHT SUFFIX	CLASE NEMA NEMA CLASS	
				ALUMINIO ALUMINUM	ACERO STEEL
82.5 (3.25)	58.1 (2.22)	Z	1	8A	12C/16B
82.5 (3.25)	56.5 (2.22)	Z	1	8C/12A	12C/16B
101.6 (4)	75.6 (2.98)	Z	2	8C/12A	12C/16B
101.6 (4)	75.6 (2.98)	Z	2	12B	12C/16B
114.3 (4.5)	88.3 (3.48)	Z	3	12B	12C/16B
127.0 (5)	101.4 (3.98)	Z	5	12C	20A
152.4 (6)	126.4 (4.98)	Z	6	16C	20C

FORM "Z" SECTIONS

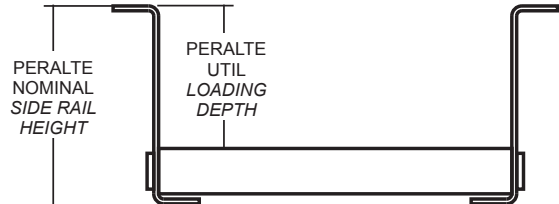

TYPE DATE SHOULD BE OMITED (ZA, ZB)

SECCIONES TIPO "C" CON CEJA HACIA ADENTRO

PERALTE NOMINAL SIDE RAIL HEIGHT	PERALTE UTIL LOADING DEPTH	PERFIL TIPO RAIL TYPE	SUBFIJO P/PERALTE RAIL HEIGHT SUFFIX	CLASE NEMA NEMA CLASS	
				ALUMINIO ALUMINUM	ACERO STEEL
82.5 (3.25)	56.5 (2.22)	C	1	8A	12B
101.6 (4)	75.6 (2.98)	C	2	12B	12C/16B
114.3 (4.5)	88.3 (3.48)	C	3	8C/12A	12C/16B
127.0 (5)	101.4 (3.98)	C	5	8C/12A	16B
152.4 (6)	126.4 (4.98)	C	6	16C	20B
152.4 (6)	126.4 (4.98)	C	6	20C	20B

FORM "C" FLANGE IN SECTIONS

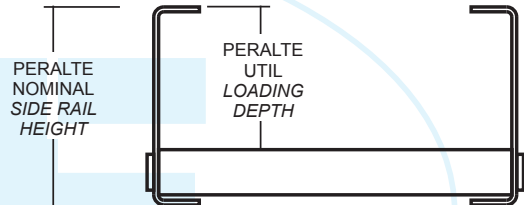

SECCIONES TIPO "I"

PERALTE NOMINAL SIDE RAIL HEIGHT	PERALTE UTIL LOADING DEPTH	PERFIL TIPO RAIL TYPE	SUBFIJO P/PERALTE RAIL HEIGHT SUFFIX	CLASE NEMA NEMA CLASS	
				ALUMINIO ALUMINUM	
101.6 (4)	75.6 (2.98)	IL	2	8C/12A	
104.6 (4.120)	78.6 (3.10)	IM	2	16C	
106.7 (4.200)	80.7 (3.17)	IP	2	20B	
127 (5)	101.4 (3.98)	IL	5	12B	
152.4 (6)	126.4 (4.98)	IM	6	20C	
152.4 (6)	126.4 (4.98)	IP	6	20C	

FORM "I" SECTIONS

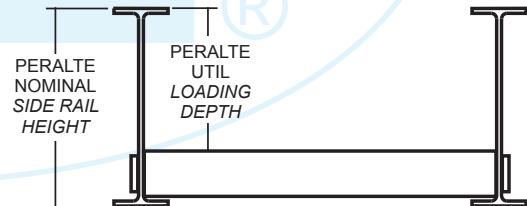

TODOS LOS ACCESORIOS EN PERFIL "I" SE FABRICAN EXTRUCTURAL / ALL THE ACCESSORIES IN PROFILE "I" ARE MANUFACTURED EXTRUCTURAL

PERFIL I SOLO EN ALUMINIO / FORM ALUMINUM ONLY

PERFIL I FABRICADO EN LIGERO, MEDIANO Y PESADO / PROFILE I MANUFACTURED IN LIGHT, MEDIUM AND HEAVY

MATERIALES Y ACABADOS DISPONIBLES:

- A: ALUMINIO ALEACION AA-6063 ACABADO NATURAL
- GI : ACERO AL CARBONO GALVANIZADO POR INMERSION EN CALIENTE SEGUN ASTM A 123
- GE : ACERO AL CARBONO GALVANIZADO ELECTROLITICO SEGUN ASTM B 633
- T : ACERO AL CARBONO TROPICALIZADO
- PVC: ACERO AL CARBONO RECUBIERTO CON PVC SEGUN NEMA RN 1
- PVA : ALUMINIO RECUBIERTO CON PVC SEGUN NEMA RN 1
- AI : ACERO INOXIDABLE ACABADO NATURAL
- G: ACERO GALVANIZADO

MATERIALS & FINISHES AVAILABLE :

- A: AA-6063 NATURAL FINISHED ALUMINUM
- GI : HOT DIP GALVANIZED STEEL UNDER ASTM A 123
- GE : ELECTROGALVANIZED STEEL UNDER ASTM B 633
- T : CHROMIUM-ZINC COATED STEEL
- PVC: PVC COATED STEEL UNDER NEMA RN 1
- PVA: PVC COATED ALUMINUM UNDER NEMA RN 1
- AI : NATURAL FINISHED STAINLESS STEEL
- G: GALVANIZED STEEL

PARA MATERIALES Y ACABADOS NO INDICADOS CONSULTE NUESTRO DEPARTAMENTO DE INGENIERIA / FOR MATERIALS AND FINISHES NOT SHOWED. PLEASE CONSULT OUT TECHNICAL DEPARTMENT

TODAS LAS DIMENSIONES EN mm (Pulg) / ALL DIMENSIONS ARE IN mm (Inch)

PUEDEN SER SUJETOS A MODIFICACION SIN PREVIO AVISO / MAY BE SUBJECT TO MODIFICATION WITHOUT NOTICE



TRAMO RECTO

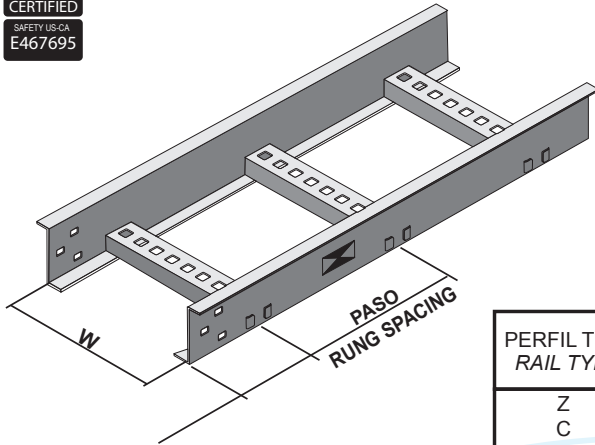

STRAIGHT SECTION

CH Z -12 09-1GI

- MATERIAL Y ACABADO (VER PAG 2)
- MATERIAL & FINISHES (SEE PAGE 2)
- SUBFIJO P/PERALTE (VER PAG 2)
- RAIL HEIGHT SUFFIX (SEE PAGE 2)
- PASO RUNG SPACING
- ANCHO WIDTH
- PERFIL TIPO (VER PAGINA 2)
- RAIL TYPE (SEE PAGE 2)
- TRAMO RECTO STRAIGHT SECTION

LONGITUDES ESTANDARD EN METROS (PIES)
STANDARD LENGHT IN METERS (FEETS)

PERFIL TIPO RAIL TYPE	MATERIAL Y ACABADO VER PAGINA 2 MATERIAL AND FINISH SEE PAGE 2						
	A	GI	GE	T	PVC	PVA	AI
Z	3.66 (12)	3.66 (12)	3.66 (12)	3.66 (12)	3.05 (10)	3.05 (10)	3.66 (12)
C	3.66 (12)	3.66 (12)	3.66(12)	3.66(12)	3.05(10)	3.05(10)	3.66(12)
I	3.66 (12)					3.05(10)	

PARA LONGITUDES DIFERENTES CONSULTE NUESTRO DEPARTAMENTO DE INGENIERIA
FOR OTHER LENGHT PLEASE CONSULT OUR TECHNICAL DEPARTMENT

ANCHO W WIDTH W	PASO RUNG SPACING			PASO RUNG SPACING		
	152.4 (6)	228.6 (9)	304.8 (12)	152.4 (6)	228.6 (9)	304.8 (12)
101.6 (4)	CHZ-0406	CHZ-0409	CHZ-0412	CHC-0406	CHC-0409	CHC-0412
152.4 (6)	CHZ-0606	CHZ-0609	CHZ-0612	CHC-0606	CHC-0609	CHC-0612
228.9 (9)	CHZ-0906	CHZ-0909	CHZ-0912	CHC-0906	CHC-0909	CHC-0912
304.8 (12)	CHZ-1206	CHZ-1209	CHZ-1212	CHC-1206	CHC-1209	CHC-1212
406.4 (16)	CHZ-1606	CHZ-1609	CHZ-1612	CHC-1606	CHC-1609	CHC-1612
457.2 (18)	CHZ-1806	CHZ-1809	CHZ-1812	CHC-1806	CHC-1809	CHC-1812
508.0 (20)	CHZ-2006	CHZ-2009	CHZ-2012	CHC-2006	CHC-2009	CHC-2012
609.6 (24)	CHZ-2406	CHZ-2409	CHZ-2412	CHC-2406	CHC-2409	CHC-2412
762.0 (30)	CHZ-3006	CHZ-3009	CHZ-3012	CHC-3006	CHC-3009	CHC-3012
914.4 (36)	CHZ-3606	CHZ-3609	CHZ-3612	CHC-3606	CHC-3609	CHC-3612

ANCHO W WIDTH W	PASO RUNG SPACING		
	152.4 (6)	228.6 (9)	304.8 (12)
101.6 (4)	CHI-0406	CHI-0409	CHI-0412
152.4 (6)	CHI-0606	CHI-0609	CHI-0612
228.9 (9)	CHI-0906	CHI-0909	CHI-0912
304.8 (12)	CHI-1206	CHI-1209	CHI-1212
406.4 (16)	CHI-1606	CHI-1609	CHI-1612
457.2 (18)	CHI-1806	CHI-1809	CHI-1812
508.0 (20)	CHI-2006	CHI-2009	CHI-2012
609.6 (24)	CHI-2406	CHI-2409	CHI-2412
762.0 (30)	CHI-3006	CHI-3009	CHI-3012
914.4 (36)	CHI-3606	CHI-3609	CHI-3612

INCLUYE 2 CONECTORES Y TORNILLERIA / TWO CONNECTOR AND HARDWARE INCLUDED
TODAS LAS DIMENSIONES EN mm (Pulg) / ALL DIMENSIONS ARE IN mm (Inch)
PUEDE SER SUJETO A MODIFICACION SIN PREVIO AVISO / MAY BE SUBJECT TO MODIFICATION WITHOUT NOTICE

CURVA HORIZONTAL A 45° Y 90°

DISEÑO RADIAL PARA PERFIL Z
RADIAL DESIGN FOR RAIL TYPE Z

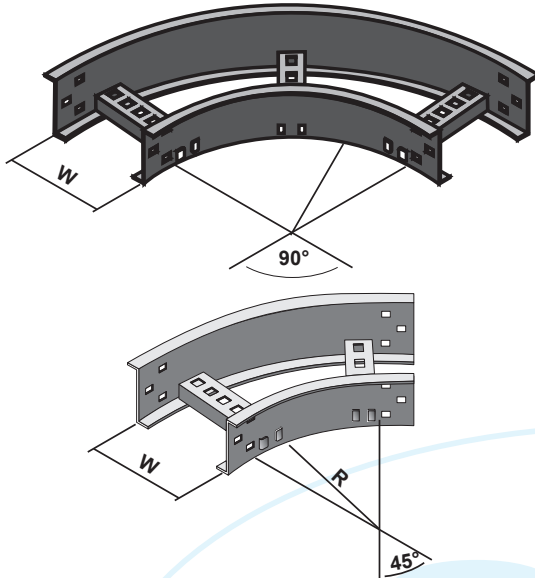

45° & 90° HORIZONTAL BEND

DISEÑO ESTRUCTURAL PARA PERFIL "Z", "C" E "I"
SEGMENTED DESIGN FOR RAIL TYPE "Z", "C" & "I"

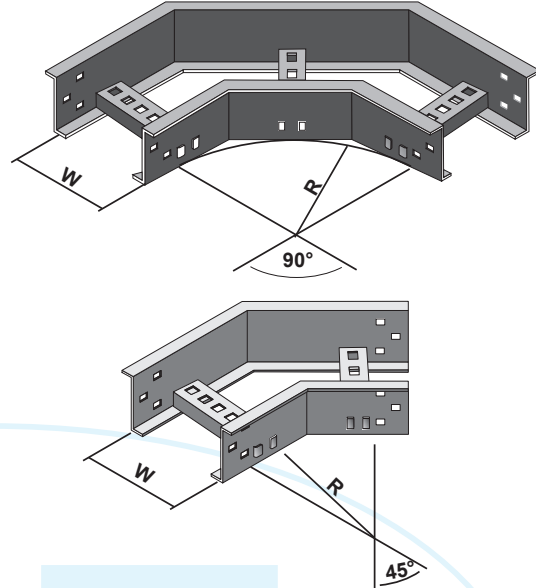

VH Z - 12R890-1GI E

- DISEÑO E = ESTRUCTURAL, EN CASO RADIAL OMITIR / DESIGN E = SEGMENTED, VOID IF RADIAL
- MATERIAL Y ACABADO (VER PAG 2) / MATERIAL & FINISHES (SEE PAGE 2)
- SUBFIJO P/PERALTE (VER PAG 2) / RAIL HEIGHT SUFFIX (SEE PAGE 2)
- ANGULO DE LA CURVA / ANGLE BEND
- RADIO RADIUS
- ANCHO WIDTH
- PERFIL TIPO (VER PAGINA 2) / RAIL TYPE (SEE PAGE 2)
- CURVA HORIZONTAL / HORIZONTAL BEND

NUMEROS DE CATALOGO PARA CURVA A 90° 90° BEND CATALOG NUMBER

ANCHO W WIDTH W	RADIO RADIUS			
	203.2 (8)	304.8 (12)	609.6 (24)	914.4 (36)
101.6 (4)	VH-04R890	VH-04R1290	VH-04R2490	VH-04R3690
152.4 (6)	VH-06R890	VH-06R1290	VH-06R2490	VH-06R3690
228.9 (9)	VH-09R890	VH-09R1290	VH-09R2490	VH-09R3690
304.8 (12)	VH-12R890	VH-12R1290	VH-12R2490	VH-12R3690
406.4 (16)	VH-16R890	VH-16R1290	VH-16R2490	VH-16R3690
457.2 (18)	VH-18R890	VH-18R1290	VH-18R2490	VH-18R3690
508.0 (20)	VH-20R890	VH-20R1290	VH-20R2490	VH-20R3690
609.6 (24)	VH-24R890	VH-24R1290	VH-24R2490	VH-24R3690
762.0 (30)	VH-30R890	VH-30R1290	VH-30R2490	VH-30R3690
914.4 (36)	VH-36R890	VH-36R1290	VH-36R2490	VH-36R3690

NUMEROS DE CATALOGO PARA CURVA A 45° 45° BEND CATALOG NUMBER

ANCHO W WIDTH W	RADIO RADIUS			
	203.2 (8)	304.8 (12)	609.6 (24)	914.4 (36)
101.6 (4)	VH-04R845	VH-04R1245	VH-04R2445	VH-04R3645
152.4 (6)	VH-06R845	VH-06R1245	VH-06R2445	VH-06R3645
228.9 (9)	VH-09R845	VH-09R1245	VH-09R2445	VH-09R3645
304.8 (12)	VH-12R845	VH-12R1245	VH-12R2445	VH-12R3645
406.4 (16)	VH-16R845	VH-16R1245	VH-16R2445	VH-16R3645
457.2 (18)	VH-18R845	VH-18R1245	VH-18R2445	VH-18R3645
508.0 (20)	VH-20R845	VH-20R1245	VH-20R2445	VH-20R3645
609.6 (24)	VH-24R845	VH-24R1245	VH-24R2445	VH-24R3645
762.0 (30)	VH-30R845	VH-30R1245	VH-30R2445	VH-30R3645
914.4 (36)	VH-36R845	VH-36R1245	VH-36R2445	VH-36R3645

INCLUYE 2 CONECTORES Y TORNILLERIA / TWO CONNECTORS AND HARDWARE INCLUDED

TODAS LAS DIMENSIONES EN mm (Pulg) / ALL DIMENSIONS ARE IN mm (Inch)

PUEDEN SER SUJETOS A MODIFICACION SIN PREVIO AVISO / MAY BE SUBJECT TO MODIFICATION WITHOUT NOTICE



CURVA VERTICAL EXTERIOR A 45° Y 90°

DISEÑO RADIAL PARA PERFIL Z
RADIAL DESIGN FOR RAIL TYPE Z

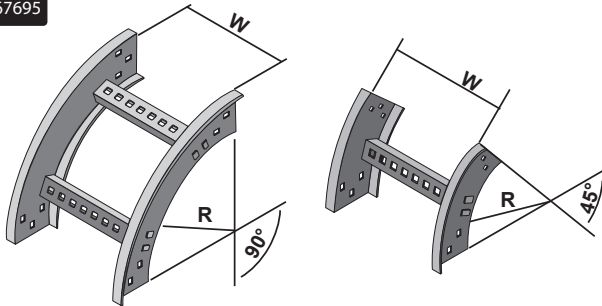

45° & 90° OUTSIDE VERTICAL BEND

DISEÑO ESTRUCTURAL PARA PERFIL "Z", "C" E "I"
SEGMENTED DESIGN FOR RAIL TYPE "Z", "C" & "I"

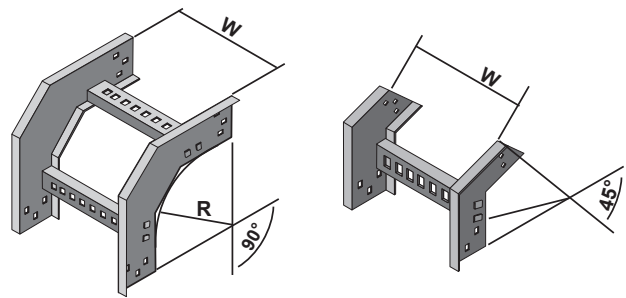

VE Z -12R8 90-1GI E

- DISEÑO E = ESTRUCTURAL, EN CASO RADIAL OMITIR / DESIGN E = SEGMENTED, VOID IF RADIAL
- MATERIAL Y ACABADO (VER PAG 2) / MATERIAL & FINISHES (SEE PAGE 2)
- SUBFIJO P/PERALTE (VER PAG 2) / RAIL HEIGHT SUFFIX (SEE PAGE 2)
- ANGULO DE LA CURVA / ANGLE BEND
- RADIO RADIUS
- ANCHO WIDTH
- PERFIL TIPO (VER PAGINA 2) / RAIL TYPE (SEE PAGE 2)
- CURVA VERTICAL EXTERIOR / OUTSIDE VERTICAL BEND

NUMEROS DE CATALOGO PARA CURVA A 90° 90° BEND CATALOG NUMBER

ANCHO W WIDTH W	RADIO RADIUS			
	203.2 (8)	304.8 (12)	609.6 (24)	914.4 (36)
101.6 (4)	VE-04R890	VE-04R1290	VE-04R2490	VE-04R3690
152.4 (6)	VE-06R890	VE-06R1290	VE-06R2490	VE-06R3690
228.9 (9)	VE-09R890	VE-09R1290	VE-09R2490	VE-09R3690
304.8 (12)	VE-12R890	VE-12R1290	VE-12R2490	VE-12R3690
406.4 (16)	VE-16R890	VE-16R1290	VE-16R2490	VE-16R3690
457.2 (18)	VE-18R890	VE-18R1290	VE-18R2490	VE-18R3690
508.0 (20)	VE-20R890	VE-20R1290	VE-20R2490	VE-20R3690
609.6 (24)	VE-24R890	VE-24R1290	VE-24R2490	VE-24R3690
762.0 (30)	VE-30R890	VE-30R1290	VE-30R2490	VE-30R3690
914.4 (36)	VE-36R890	VE-36R1290	VE-36R2490	VE-36R3690

NUMEROS DE CATALOGO PARA CURVA A 45° 45° BEND CATALOG NUMBER

ANCHO W WIDTH W	RADIO RADIUS			
	203.2 (8)	304.8 (12)	609.6 (24)	914.4 (36)
101.6 (4)	VE-04R845	VE-04R1245	VE-04R2445	VE-04R3645
152.4 (6)	VE-06R845	VE-06R1245	VE-06R2445	VE-06R3645
228.9 (9)	VE-09R845	VE-09R1245	VE-09R2445	VE-09R3645
304.8 (12)	VE-12R845	VE-12R1245	VE-12R2445	VE-12R3645
406.4 (16)	VE-16R845	VE-16R1245	VE-16R2445	VE-16R3645
457.2 (18)	VE-18R845	VE-18R1245	VE-18R2445	VE-18R3645
508.0 (20)	VE-20R845	VE-20R1245	VE-20R2445	VE-20R3645
609.6 (24)	VE-24R845	VE-24R1245	VE-24R2445	VE-24R3645
762.0 (30)	VE-30R845	VE-30R1245	VE-30R2445	VE-30R3645
914.4 (36)	VE-36R845	VE-36R1245	VE-36R2445	VE-36R3645

INCLUYE 2 CONECTORES Y TORNILLERIA / TWO CONNECTORS AND HARDWARE INCLUDED

TODAS LAS DIMENSIONES EN mm (Pulg) / ALL DIMENSIONS ARE IN mm (Inch)

PUEDEN SER SUJETOS A MODIFICACION SIN PREVIO AVISO / MAY BE SUBJECT TO MODIFICATION WITHOUT NOTICE

CURVA VERTICAL INTERIOR A 45° Y 90°

DISEÑO RADIAL PARA PERFIL Z
RADIAL DESIGN FOR RAIL TYPE Z

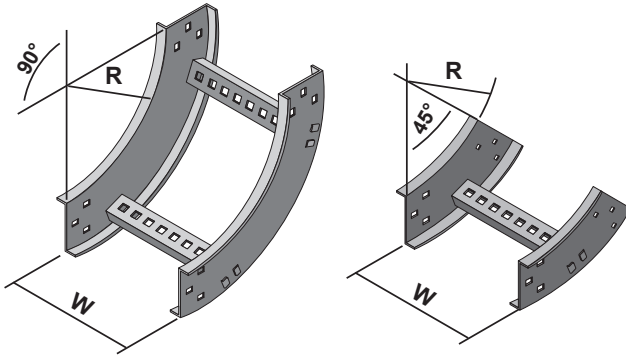

45° & 90° INSIDE VERTICAL BEND

DISEÑO ESTRUCTURAL PARA PERFIL "Z", "C" E "I"
SEGMENTED DESIGN FOR RAIL TYPE "Z", "C" & "I"

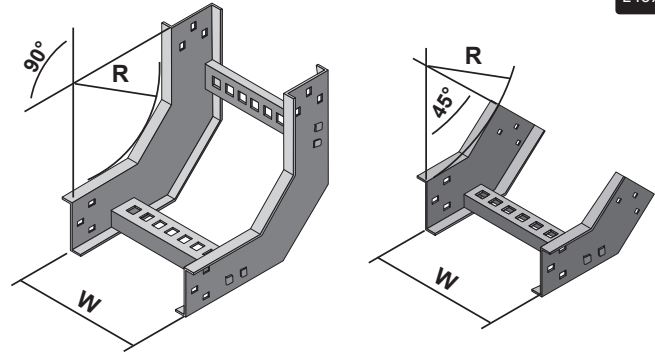

VI Z-12R890-1G1E

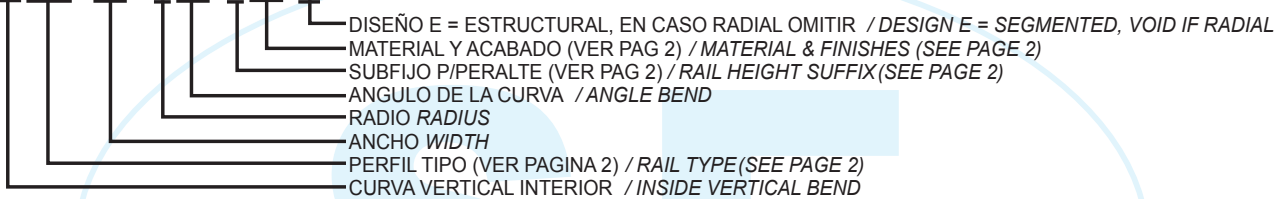

NUMEROS DE CATALOGO PARA CURVA A 90° 90° BEND CATALOG NUMBER

ANCHO W WIDTH W	RADIO RADIUS			
	203.2 (8)	304.8 (12)	609.6 (24)	914.4 (36)
101.6 (4)	VI-04R890	VI-04R1290	VI-04R2490	VI-04R3690
152.4 (6)	VI-06R890	VI-06R1290	VI-06R2490	VI-06R3690
228.9 (9)	VI-09R890	VI-09R1290	VI-09R2490	VI-09R3690
304.8 (12)	VI-12R890	VI-12R1290	VI-12R2490	VI-12R3690
406.4 (16)	VI-16R890	VI-16R1290	VI-16R2490	VI-16R3690
457.2 (18)	VI-18R890	VI-18R1290	VI-18R2490	VI-18R3690
508.0 (20)	VI-20R890	VI-20R1290	VI-20R2490	VI-20R3690
609.6 (24)	VI-24R890	VI-24R1290	VI-24R2490	VI-24R3690
762.0 (30)	VI-30R890	VI-30R1290	VI-30R2490	VI-30R3690
914.4 (36)	VI-36R890	VI-36R1290	VI-36R2490	VI-36R3690

NUMEROS DE CATALOGO PARA CURVA A 45° 45° BEND CATALOG NUMBER

ANCHO W WIDTH W	RADIO RADIUS			
	203.2 (8)	304.8 (12)	609.6 (24)	914.4 (36)
101.6 (4)	VI-04R845	VI-04R1245	VI-04R2445	VI-04R3645
152.4 (6)	VI-06R845	VI-06R1245	VI-06R2445	VI-06R3645
228.9 (9)	VI-09R845	VI-09R1245	VI-09R2445	VI-09R3645
304.8 (12)	VI-12R845	VI-12R1245	VI-12R2445	VI-12R3645
406.4 (16)	VI-16R845	VI-16R1245	VI-16R2445	VI-16R3645
457.2 (18)	VI-18R845	VI-18R1245	VI-18R2445	VI-18R3645
508.0 (20)	VI-20R845	VI-20R1245	VI-20R2445	VI-20R3645
609.6 (24)	VI-24R845	VI-24R1245	VI-24R2445	VI-24R3645
762.0 (30)	VI-30R845	VI-30R1245	VI-30R2445	VI-30R3645
914.4 (36)	VI-36R845	VI-36R1245	VI-36R2445	VI-36R3645

INCLUYE 2 CONECTORES Y TORNILLERIA / TWO CONNECTORS AND HARDWARE INCLUDED

TODAS LAS DIMENSIONES EN mm (Pulg) / ALL DIMENSIONS ARE IN mm (Inch)

PUEDEN SER SUJETOS A MODIFICACION SIN PREVIO AVISO / MAY BE SUBJECT TO MODIFICATION WITHOUT NOTICE



"T" HORIZONTAL

DISEÑO RADIAL PARA PERFIL Z
RADIAL DESIGN FOR RAIL TYPE Z

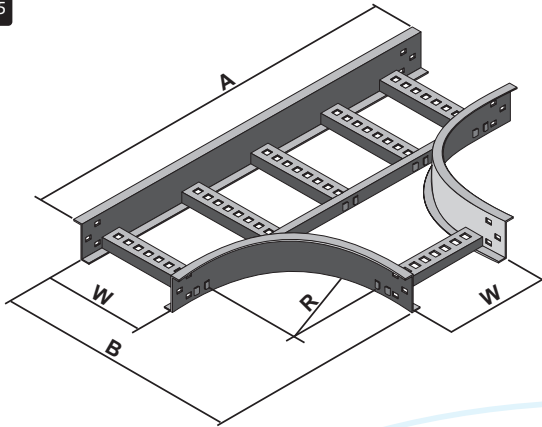

HORIZONTAL TEE

DISEÑO ESTRUCTURAL PARA PERFIL "Z", "C" E "I"
SEGMENTED DESIGN FOR RAIL TYPE "Z", "C" & "I"

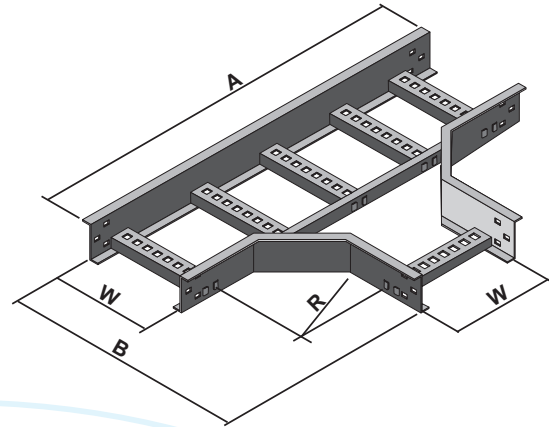

TH Z-12 R8-1GI E

- DISEÑO E = ESTRUCTURAL, EN CASO RADIAL OMITIR / DESIGN E = SEGMENTED, VOID IF RADIAL
- MATERIAL Y ACABADO (VER PAG 2) / MATERIAL & FINISHES (SEE PAGE 2)
- SUBFIJO P/PERALTE (VER PAG 2) / RAIL HEIGHT SUFFIX (SEE PAGE 2)
- RADIO RADIUS
- ANCHO WIDTH
- PERFIL TIPO (VER PAGINA 2) / RAIL TYPE (SEE PAGE 2)
- "T" HORIZONTAL HORIZONTAL "T"

ANCHO W WIDTH W	RADIO 203.2 RADIUS (8) SOLO RADIAL RADIAL ONLY			RADIO 304.8 RADIUS (12)		
	No DE CATALOGO CATALOG NUMBER	A	B	No DE CATALOGO CATALOG NUMBER	A	B
101.6 (4)	TH-04R8	731 (28.78)	416 (16.39)	TH-04R12	864 (34)	518 (20.39)
152.4 (6)	TH-06R8	782 (30.78)	467 (18.39)	TH-06R12	914 (36)	569 (22.39)
228.9 (9)	TH-09R8	858 (33.78)	543 (21.39)	TH-09R12	991 (39)	645 (25.39)
304.8 (12)	TH-12R8	934 (36.78)	619 (24.39)	TH-12R12	1067 (45.98)	721 (28.39)
406.4 (16)	TH-16R8	1036 (40.78)	721 (28.39)	TH-16R12	1168 (45.98)	823 (32.39)
457.2 (18)	TH-18R8	1086 (42.78)	772 (30.39)	TH-18R12	1219 (47.99)	873 (34.39)
508.0 (20)	TH-20R8	1137 (44.78)	823 (32.39)	TH-20R12	1270 (50.00)	924 (36.39)
609.6 (24)	TH-24R8	1239 (48.78)	924 (36.39)	TH-24R12	1371 (53.97)	1026 (40.39)
762.0 (30)	TH-30R8	1391 (54.78)	1077 (42.39)	TH-30R12	1524 (60.00)	1178 (46.39)
914.4 (36)	TH-36R8	1543 (60.78)	1229 (48.39)	TH-36R12	1676 (65.98)	1331 (52.39)

ANCHO W WIDTH W	RADIO 609.6 RADIUS (24)			RADIO 914.4 RADIUS (36)		
	No DE CATALOGO CATALOG NUMBER	A	B	No DE CATALOGO CATALOG NUMBER	A	B
101.6 (4)	TH-04R24	1544 (60.78)	823 (32.39)	TH-04R36	2153 (84.78)	1127 (44.39)
152.4 (6)	TH-06R24	1595 (62.78)	873 (34.39)	TH-06R36	2204 (86.78)	1178 (46.39)
228.9 (9)	TH-09R24	1671 (65.78)	950 (37.39)	TH-09R36	2280 (89.78)	1254 (49.39)
304.8 (12)	TH-12R24	1747 (68.78)	1030 (40.39)	TH-12R36	2357 (92.78)	1331 (52.39)
406.4 (16)	TH-16R24	1849 (72.78)	1127 (44.39)	TH-16R36	2458 (96.78)	1432 (56.39)
457.2 (18)	TH-18R24	1899 (74.78)	1178 (46.39)	TH-18R36	2509 (98.78)	1483 (58.39)
508.0 (20)	TH-20R24	1950 (76.78)	1229 (48.39)	TH-20R36	2560 (100.78)	1534 (60.39)
609.6 (24)	TH-24R24	2052 (80.78)	1331 (52.39)	TH-24R36	2661 (104.78)	1635 (64.39)
762.0 (30)	TH-30R24	2204 (86.78)	1483 (58.39)	TH-30R36	2814 (110.78)	1788 (70.39)
914.4 (36)	TH-36R24	2357 (92.78)	1635 (64.39)	TH-36R36	2966 (116.78)	1940 (76.39)

INCLUYE 2 CONECTORES Y TORNILLERIA / TWO CONNECTORS AND HARDWARE INCLUDED

TODAS LAS DIMENSIONES EN mm (Pulg) / ALL DIMENSIONS ARE IN mm (Inch)

PUEDEN SER SUJETOS A MODIFICACION SIN PREVIO AVISO / MAY BE SUBJECT TO MODIFICATION WITHOUT NOTICE

"X" HORIZONTAL

DISEÑO RADIAL PARA PERFIL Z
RADIAL DESIGN FOR RAIL TYPE Z

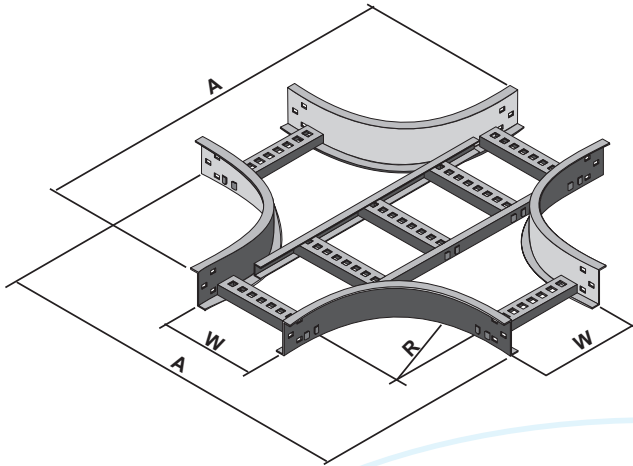

HORIZONTAL CROSS

DISEÑO ESTRUCTURAL PARA PERFIL "Z", "C" E "I"
SEGMENTED DESIGN FOR RAIL TYPE "Z", "C" & "I"

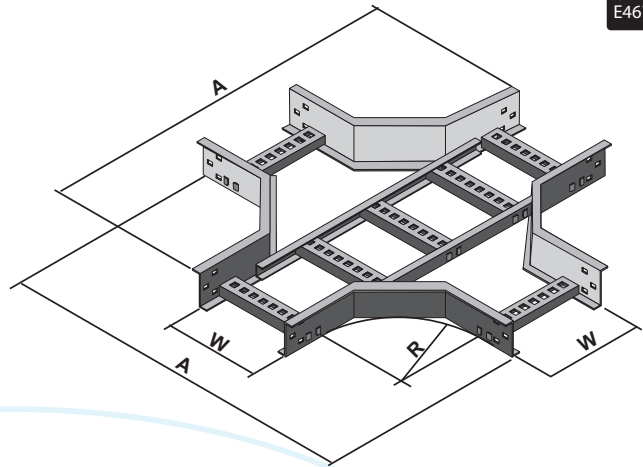

XH Z - 12R8-1GI E

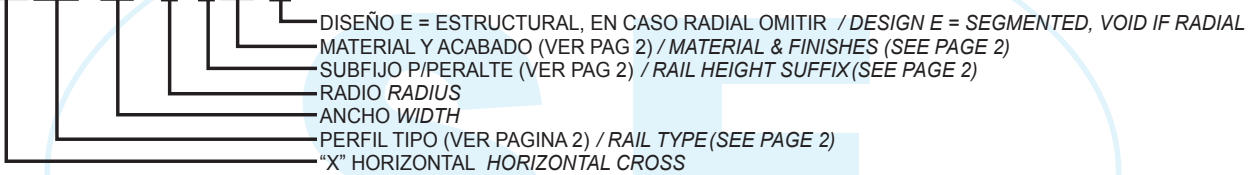

ANCHO W WIDTH W	RADIO 203.2 RADIUS (8)		RADIO 304.8 RADIUS (12)	
	No DE CATALOGO CATALOG NUMBER	A	No DE CATALOGO CATALOG NUMBER	A
101.6 (4)	XH-04R8	731 (28.78)	XH-04R12	864 (34)
152.4 (6)	XH-06R8	782 (30.78)	XH-06R12	914 (36)
228.9 (9)	XH-09R8	858 (33.78)	XH-09R12	991 (39)
304.8 (12)	XH-12R8	934 (36.78)	XH-12R12	1067 (42.01)
406.4 (16)	XH-16R8	1036 (40.78)	XH-16R12	1168 (45.98)
457.2 (18)	XH-18R8	1086 (42.78)	XH-18R12	1219 (47.99)
508.0 (20)	XH-20R8	1137 (44.78)	XH-20R12	1270 (50.00)
609.6 (24)	XH-24R8	1239 (48.78)	XH-24R12	1371 (53.97)
762.0 (30)	XH-30R8	1391 (54.78)	XH-30R12	1524 (60.00)
914.4 (36)	XH-36R8	1543 (60.78)	XH-36R12	1676 (65.98)

ANCHO W WIDTH W	RADIO 609.6 RADIUS (24)		RADIO 914.4 RADIUS (36)	
	No DE CATALOGO CATALOG NUMBER	A	No DE CATALOGO CATALOG NUMBER	A
101.6 (4)	XH-04R24	1544 (60.78)	XH-04R36	2153 (84.78)
152.4 (6)	XH-06R24	1595 (62.78)	XH-06R36	2204 (86.78)
228.9 (9)	XH-09R24	1671 (65.78)	XH-09R36	2280 (89.78)
304.8 (12)	XH-12R24	1747 (68.78)	XH-12R36	2357 (92.78)
406.4 (16)	XH-16R24	1849 (72.78)	XH-16R36	2458 (96.78)
457.2 (18)	XH-18R24	1899 (74.78)	XH-18R36	2509 (98.78)
508.0 (20)	XH-20R24	1950 (76.78)	XH-20R36	2560 (100.78)
609.6 (24)	XH-24R24	2052 (80.78)	XH-24R36	2661 (104.78)
762.0 (30)	XH-30R24	2204 (86.78)	XH-30R36	2814 (110.78)
914.4 (36)	XH-36R24	2357 (92.78)	XH-36R36	2966 (116.78)

INCLUYE 2 CONECTORES Y TORNILLERIA / TWO CONNECTORS AND HARDWARE INCLUDED

TODAS LAS DIMENSIONES EN mm (Pulg) / ALL DIMENSIONS ARE IN mm (Inch)

PUEDEN SER SUJETOS A MODIFICACION SIN PREVIO AVISO / MAY BE SUBJECT TO MODIFICATION WITHOUT NOTICE



"T" VERTICAL

DISEÑO RADIAL PARA PERFIL Z,
RADIOS 203.2, 304.8, 609.6 Y 914.4 (8, 12, 24 Y 36)
RADIAL DESIGN FOR RAIL TYPE Z,
RADIUS 203.2 & 304.8 (8 & 12)

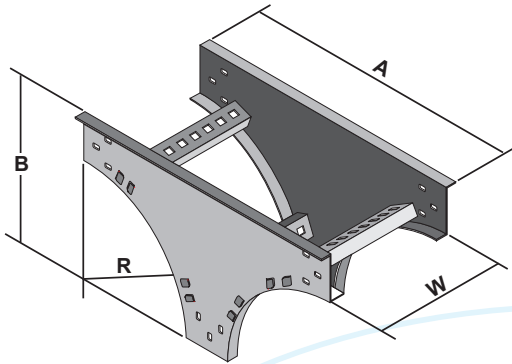

VERTICAL TEE

DISEÑO ESTRUCTURAL PARA PERFIL "Z" "C" E "I"
RADIOS 203.2, 304.8, 609.6 Y 914.4 (8, 12, 24 Y 36)
SEGMENTED DESIGN FOR RAIL TYPE "Z" "C" & "I"
RADIUS 304.8, 609.6 & 914.4 (12, 24 & 36)

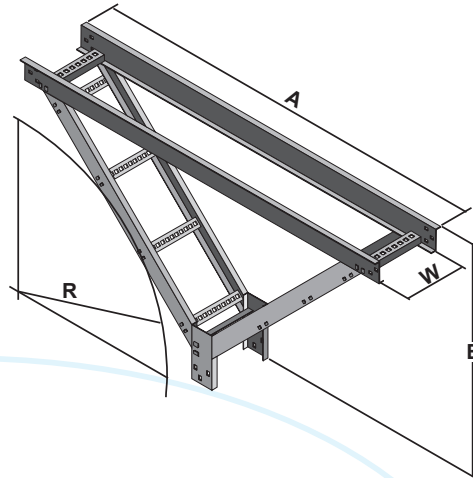

TV Z-12R8-1GI E

- DISEÑO E = ESTRUCTURAL, EN CASO RADIAL OMITIR / DESIGN E = SEGMENTED, VOID IF RADIAL
- MATERIAL Y ACABADO (VER PAG 2) / MATERIAL & FINISHES (SEE PAGE 2)
- SUBFIJO P/PERALTE (VER PAG 2) / RAIL HEIGHT SUFFIX (SEE PAGE 2)
- RADIO RADIUS
- ANCHO WIDTH
- PERFIL TIPO (VER PAGINA 2) / RAIL TYPE (SEE PAGE 2)
- "T" VERTICAL VERTICAL "T"

NUMEROS DE CATALOGO CATALOG NUMBER

ANCHO W WIDTH W	RADIO RADIUS			
	203.2 (8)	304.8 (12)	609.6 (24)	914.4 (36)
101.6 (4)	TV-04R8	TV-04R12	TV-04R24	TV-04R36
152.4 (6)	TV-06R8	TV-06R12	TV-06R24	TV-06R36
228.9 (9)	TV-09R8	TV-09R12	TV-09R24	TV-09R36
304.8 (12)	TV-12R8	TV-12R12	TV-12R24	TV-12R36
406.4 (16)	TV-16R8	TV-16R12	TV-16R24	TV-16R36
457.2 (18)	TV-18R8	TV-18R12	TV-18R24	TV-18R36
508.0 (20)	TV-20R8	TV-20R12	TV-20R24	TV-20R36
609.6 (24)	TV-24R8	TV-24R12	TV-24R24	TV-24R36
762.0 (30)	TV-30R8	TV-30R12	TV-30R24	TV-30R36
914.4 (36)	TV-36R8	TV-36R12	TV-36R24	TV-36R36

SUBFIJO P/PERALTE HEIGHT RAIL SUFFIX	RADIO RADIUS							
	203.2 (8)		304.8 (12)		609.6 (24)		914.4 (36)	
	A	B	A	B	A	B	A	B
1	489 (19.25)	286 (11.25)	692 (27.25)	387 (15.25)	1302 (51.25)	692 (27.25)	1911 (75.25)	997 (39.25)
2	508 (20)	305 (12)	711 (28)	406 (16)	1321 (52)	711 (28)	1930 (76)	1016 (40)
3	521 (20.5)	318 (12.5)	724 (28.5)	419 (16.5)	1334 (52.5)	724 (28.5)	1943 (76.5)	1029 (40.5)
5	533 (21)	330 (13)	737 (29)	432 (17)	1346 (53)	737 (29)	1956 (77)	1041 (41)
6	559 (22)	356 (14)	762 (30)	457 (18)	1372 (54)	762 (30)	1981 (78)	1067 (42)

INCLUYE 2 CONECTORES Y TORNILLERIA / TWO CONNECTORS AND HARDWARE INCLUDED

TODAS LAS DIMENSIONES EN mm (Pulg) / ALL DIMENSIONS ARE IN mm (Inch)

PUEDEN SER SUJETOS A MODIFICACION SIN PREVIO AVISO / MAY BE SUBJECT TO MODIFICATION WITHOUT NOTICE

"X" VERTICAL

DISEÑO RADIAL PARA PERFIL Z Y C,
RADIOS 203.2, 304.8, 609.6 Y 914.4 (8, 12, 24 Y 36)
RADIAL DESIGN FOR RAIL TYPE Z Y C,
RADIUS 203.2 & 304.8 (8 & 12)

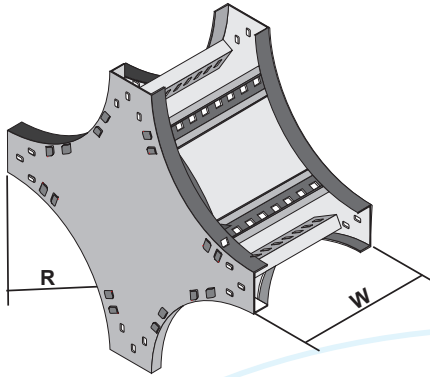

VERTICAL CROSS

DISEÑO ESTRUCTURAL PARA PERFIL "Z" "C" E "I"
RADIOS 203.2, 304.8, 609.6 Y 914.4 (8, 12, 24 Y 36)
SEGMENTED DESIGN FOR RAIL TYPE "Z" "C" & "I"
RADIUS 304.8, 609.6 & 914.4 (12, 24 & 36)

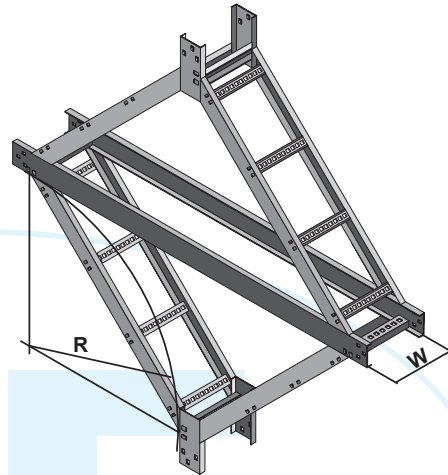

XV Z-12R8-1GI E

DISEÑO E = ESTRUCTURAL, EN CASO RADIAL OMITIR / DESIGN E = SEGMENTED, VOID IF RADIAL
MATERIAL Y ACABADO (VER PAG 2) / MATERIAL & FINISHES (SEE PAGE 2)
SUBFIJO P/PERALTE (VER PAG 2) / RAIL HEIGHT SUFFIX (SEE PAGE 2)
RADIO RADIUS
ANCHO WIDTH
PERFIL TIPO (VER PAGINA 2) / RAIL TYPE (SEE PAGE 2)
"X" VERTICAL VERTICAL CROSS

NUMEROS DE CATALOGO CATALOG NUMBER

ANCHO W WIDTH W	RADIO RADIUS			
	203.2 (8)	304.8 (12)	609.6 (24)	914.4 (36)
101.6 (4)	XV-04R8	XV-04R12	XV-04R24	XV-04R36
152.4 (6)	XV-06R8	XV-06R12	XV-06R24	XV-06R36
228.9 (9)	XV-09R8	XV-09R12	XV-09R24	XV-09R36
304.8 (12)	XV-12R8	XV-12R12	XV-12R24	XV-12R36
406.4 (16)	XV-16R8	XV-16R12	XV-16R24	XV-16R36
457.2 (18)	XV-18R8	XV-18R12	XV-18R24	XV-18R36
508.0 (20)	XV-20R8	XV-20R12	XV-20R24	XV-20R36
609.6 (24)	XV-24R8	XV-24R12	XV-24R24	XV-24R36
762.0 (30)	XV-30R8	XV-30R12	XV-30R24	XV-30R36
914.4 (36)	XV-36R8	XV-36R12	XV-36R24	XV-36R36

DIMENSION A A DIMENSION

SUBFIJO P/PERALTE HEIGHT RAIL SUFFIX	RADIO RADIUS			
	203.2 (8)	304.8 (12)	609.6 (24)	914.4 (36)
1	489 (19.25)	692 (27.25)	1302 (51.25)	1911 (75.25)
2	508 (20)	711 (28)	1321 (52)	1930 (76)
3	521 (20.5)	724 (28.5)	1334 (52.5)	1943 (76.5)
5	533 (21)	737 (29)	1346 (53)	1956 (77)
6	559 (22)	762 (30)	1372 (54)	1981 (78)

INCLUYE 2 CONECTORES Y TORNILLERIA / TWO CONNECTORS AND HARDWARE INCLUDED

TODAS LAS DIMENSIONES EN mm (Pulg) / ALL DIMENSIONS ARE IN mm (Inch)

PUEDEN SER SUJETOS A MODIFICACION SIN PREVIO AVISO / MAY BE SUBJECT TO MODIFICATION WITHOUT NOTICE



CURVA HORIZONTAL AJUSTABLE

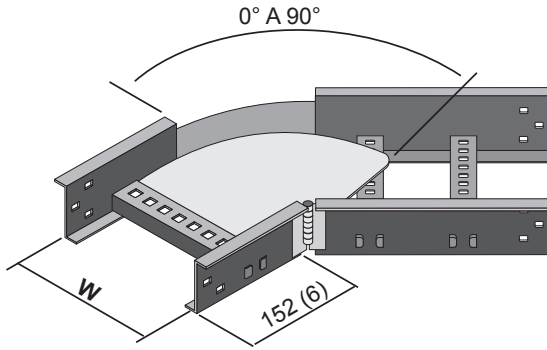

HORIZONTAL ADJUSTABLE BEND

ANCHO W WIDTH W	N° DE CATALOGO CATALOG NUMBER
101.6 (4)	CA-04
152.4 (6)	CA-06
228.9 (9)	CA-09
304.8 (12)	CA-12
406.4 (16)	CA-16
457.2 (18)	CA-18
508.0 (20)	CA-20
609.6 (24)	CA-24
762.0 (30)	CA-30
914.4 (36)	CA-36

INCLUYE 2 CONECTORES Y TORNILLERIA
TWO CONNECTORS AND HARDWARE INCLUDED
NO INCLUYE CINTAS CONDUCTORAS
BONDING JUMPERS NOT INCLUDED

CA Z -12-1GI

- MATERIAL Y ACABADO (VER PAG 2) MATERIAL & FINISHES (SEE PAGE 2)
- SUBFIJO P/PERALTE (VER PAG 2) RAIL HEIGHT SUFFIX (SEE PAGE 2)
- ANCHO WIDTH
- PERFIL TIPO (VER PAGINA 2) RAIL TYPE (SEE PAGE 2)
- CURVA HORIZONTAL AJUSTABLE HORIZONTAL ADJUSTABLE BEND
- DERECHA O IZQUIERDA RIGHT OR LEFT

DERIVACION HORIZONTAL A 45° DERECHA O IZQUIERDA

45° HORIZONTAL JUNCTION RIGHT OR LEFT

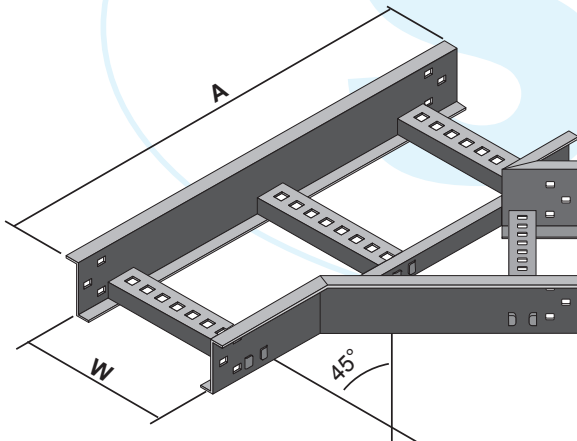

ANCHO W WIDTH W	N° DE CATALOGO CATALOG NUMBER	A
101.6 (4)	DYD-04	463 (18.2)
152.4 (6)	DYD-06	534 (21)
228.9 (9)	DYD-09	642 (25.3)
304.8 (12)	DYD-12	750 (29.5)
406.4 (16)	DYD-16	894 (35.2)
457.2 (18)	DYD-18	966 (38)
508.0 (20)	DYD-20	1037 (40.8)
609.6 (24)	DYD-24	1181 (46.5)
762.0 (30)	DYD-30	1396 (55)
914.4 (36)	DYD-36	1612 (63.5)

INCLUYE 2 CONECTORES Y TORNILLERIA
TWO CONNECTORS AND HARDWARE INCLUDED

DY DZ-12-1GI

- MATERIAL Y ACABADO (VER PAG 9) MATERIAL & FINISHES (SEE PAGE 9)
- SUBFIJO P/PERALTE (VER PAG 9) RAIL HEIGHT SUFFIX (SEE PAGE 9)
- ANCHO WIDTH
- PERFIL TIPO (VER PAGINA 9) RAIL TYPE (SEE PAGE 9)
- DERIVACION HORIZONTAL A 45° 45° HORIZONTAL JUNCTION
(D Y D PARA DERECHA D AND D TO RIGHT)
(D Y I PARA IZQUIERDA D AND I TO LEFT)

TODAS LAS DIMENSIONES EN mm (Pulg) / ALL DIMENSIONS ARE IN mm (Inch)
PUEDE SER SUJETO A MODIFICACION SIN PREVIO AVISO / MAY BE SUBJECT TO MODIFICATION WITHOUT NOTICE

REDUCCIONES

REDUCERS

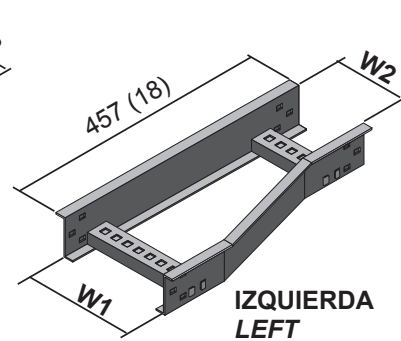
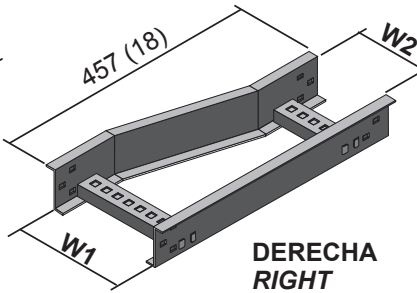
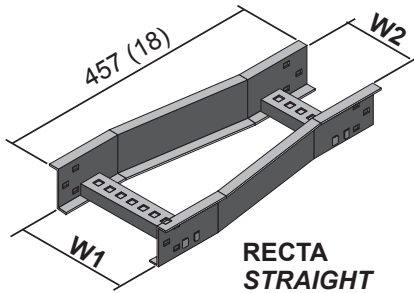

RL Z -12 09-1GI

- MATERIAL Y ACABADO (VER PAG 2) MATERIAL & FINISHES (SEE PAGE 2)
- SUBFIJO P/PERALTE (VER PAG 2) RAIL HEIGHT SUFFIX (SEE PAGE 2)
- ANCHO MENOR SMALLER WIDTH
- ANCHO MAYOR LARGER WIDTH
- PERFIL TIPO (VER PAGINA 2) RAIL TYPE (SEE PAGE 2)
- REDUCCION REDUCER
- RL = RECTA STRAIGHT
- RLD = DERECHA RIGHT
- RLI = IZQUIERDA LEFT

Nº DE CATALOGO REDUCCIONES RECTAS / STRAIGHT REDUCER CATALOG NUMBER

ANCHO W1 WIDTH W1	ANCHO MENOR W2 SMALLER WIDTH W2								
	101.6 (4)	152.4 (6)	228.9 (9)	304.8 (12)	406.4 (16)	457.2 (18)	508.0 (20)	609.6 (24)	762.0 (30)
152.4 (6)	RL-0604								
228.9 (9)	RL-0904	RL-0906							
304.8 (12)	RL-1204	RL-1206	RL-1209						
406.4 (16)	RL-1604	RL-1606	RL-1609	RL-1612					
457.2 (18)	RL-1804	RL-1806	RL-1809	RL-1812	RL-1816				
508.0 (20)	RL-2004	RL-2006	RL-2009	RL-2012	RL-2016	RL-2018			
609.6 (24)	RL-2404	RL-2406	RL-2409	RL-2412	RL-2416	RL-2418	RL-2420		
762.0 (30)	RL-3004	RL-3006	RL-3009	RL-3012	RL-3016	RL-3018	RL-3020	RL-3024	
914.4 (36)	RL-3604	RL-3606	RL-3609	RL-3612	RL-3616	RL-3618	RL-3620	RL-3624	RL-3630

Nº DE CATALOGO REDUCCIONES DERECHAS / RIGHT REDUCER CATALOG NUMBER

ANCHO W1 WIDTH W1	ANCHO MENOR W2 SMALLER WIDTH W2								
	101.6 (4)	152.4 (6)	228.9 (9)	304.8 (12)	406.4 (16)	457.2 (18)	508.0 (20)	609.6 (24)	762.0 (30)
152.4 (6)	RLD-0604								
228.9 (9)	RLD-0904	RLD-0906							
304.8 (12)	RLD-1204	RLD-1206	RLD-1209						
406.4 (16)	RLD-1604	RLD-1606	RLD-1609	RLD-1612					
457.2 (18)	RLD-1804	RLD-1806	RLD-1809	RLD-1812	RLD-1816				
508.0 (20)	RLD-2004	RLD-2006	RLD-2009	RLD-2012	RLD-2016	RLD-2018			
609.6 (24)	RLD-2404	RLD-2406	RLD-2409	RLD-2412	RLD-2416	RLD-2418	RLD-2420		
762.0 (30)	RLD-3004	RLD-3006	RLD-3009	RLD-3012	RLD-3016	RLD-3018	RLD-3020	RLD-3024	
914.4 (36)	RLD-3604	RLD-3606	RLD-3609	RLD-3612	RLD-3616	RLD-3618	RLD-3620	RLD-3624	RLD-3630

Nº DE CATALOGO REDUCCIONES IZQUIERDAS / LEFT REDUCER CATALOG NUMBER

ANCHO W1 WIDTH W1	ANCHO MENOR W2 SMALLER WIDTH W2								
	101.6 (4)	152.4 (6)	228.9 (9)	304.8 (12)	406.4 (16)	457.2 (18)	508.0 (20)	609.6 (24)	762.0 (30)
152.4 (6)	RLI-0604								
228.9 (9)	RLI-0904	RLI-0906							
304.8 (12)	RLI-1204	RLI-1206	RLI-1209						
406.4 (16)	RLI-1604	RLI-1606	RLI-1609	RLI-1612					
457.2 (18)	RLI-1804	RLI-1806	RLI-1809	RLI-1812	RLI-1816				
508.0 (20)	RLI-2004	RLI-2006	RLI-2009	RLI-2012	RLI-2016	RLI-2018			
609.6 (24)	RLI-2404	RLI-2406	RLI-2409	RLI-2412	RLI-2416	RLI-2418	RLI-2420		
762.0 (30)	RLI-3004	RLI-3006	RLI-3009	RLI-3012	RLI-3016	RLI-3018	RLI-3020	RLI-3024	
914.4 (36)	RLI-3604	RLI-3606	RLI-3609	RLI-3612	RLI-3616	RLI-3618	RLI-3620	RLI-3624	RLI-3630

INCLUYE 2 CONECTORES Y TORNILLERIA / TWO CONNECTORS AND HARDWARE INCLUDED

TODAS LAS DIMENSIONES EN mm (Pulg) / ALL DIMENSIONS ARE IN mm (Inch)

PUEDEN SER SUJETOS A MODIFICACION SIN PREVIO AVISO / MAY BE SUBJECT TO MODIFICATION WITHOUT NOTICE